

dogPACER QUICK START GUIDE



4.0

For latest info, tips, and photos go online to:

www.dogpacer.com

Congratulations! You have taken the first step in your dog's health, happiness, and a better life!

We encourage you to go online to: www.dogPACER.com to see other dog owners running their dogs and to join our Facebook community for special offers and information.

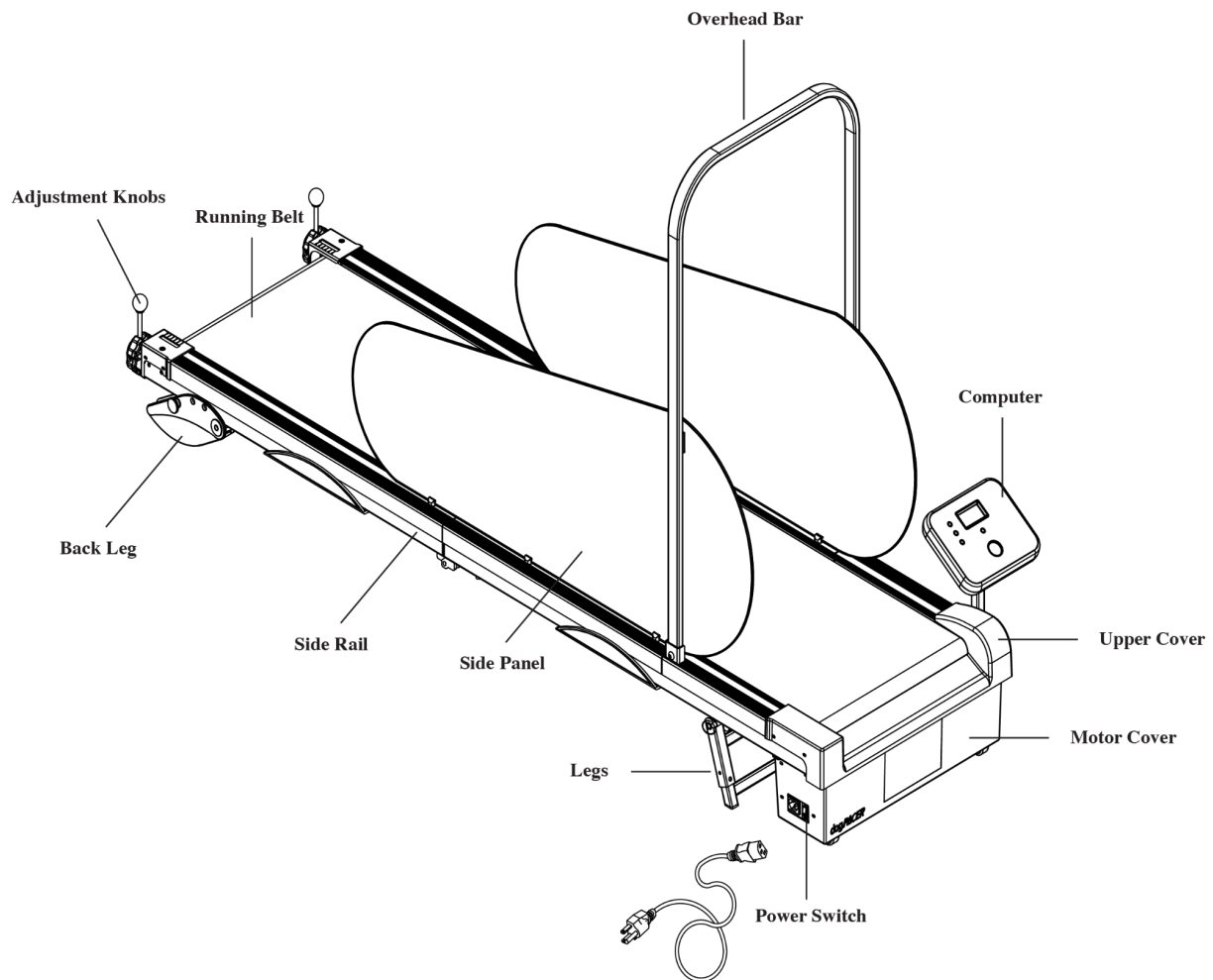

1. Protect your floors

Place a mat, rug or carpet under the dogPACER in order to protect your floor.

2. Unfold the dogPACER

Lay the treadmill on the power switch side and unfold it. (For further info check videos on www.dogpacer.com).

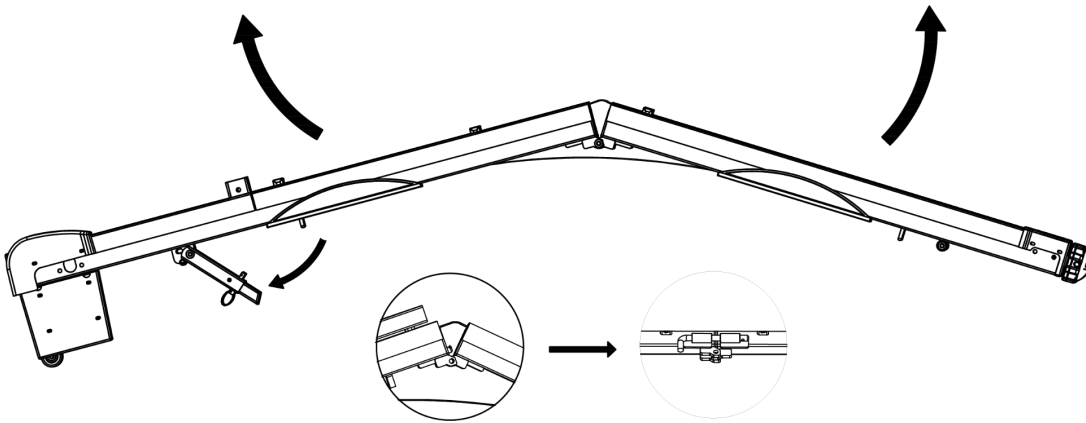

3. Locking the treadmill

- Open the legs and lock them into place using the Leg Pins (Bolt Ø6). Make sure that they are locked (see diagram below).
- After opening, while the dogPACER is on its side, slide the safety bar (Bolt Ø10*140) to the lock position.

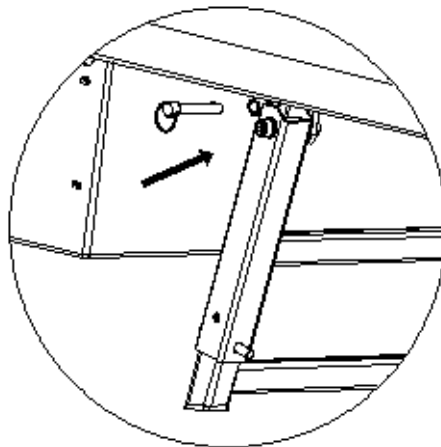

4. Connecting the Overhead Bar

Put the *overhead bar* into place and tighten the 4 screws (Bolts M6*15). The upper part can come off, if your dog is too tall. (NOTE: Please insert all the screws initially and tighten one by one using the 5mm Hex Key. Do not over tighten.)

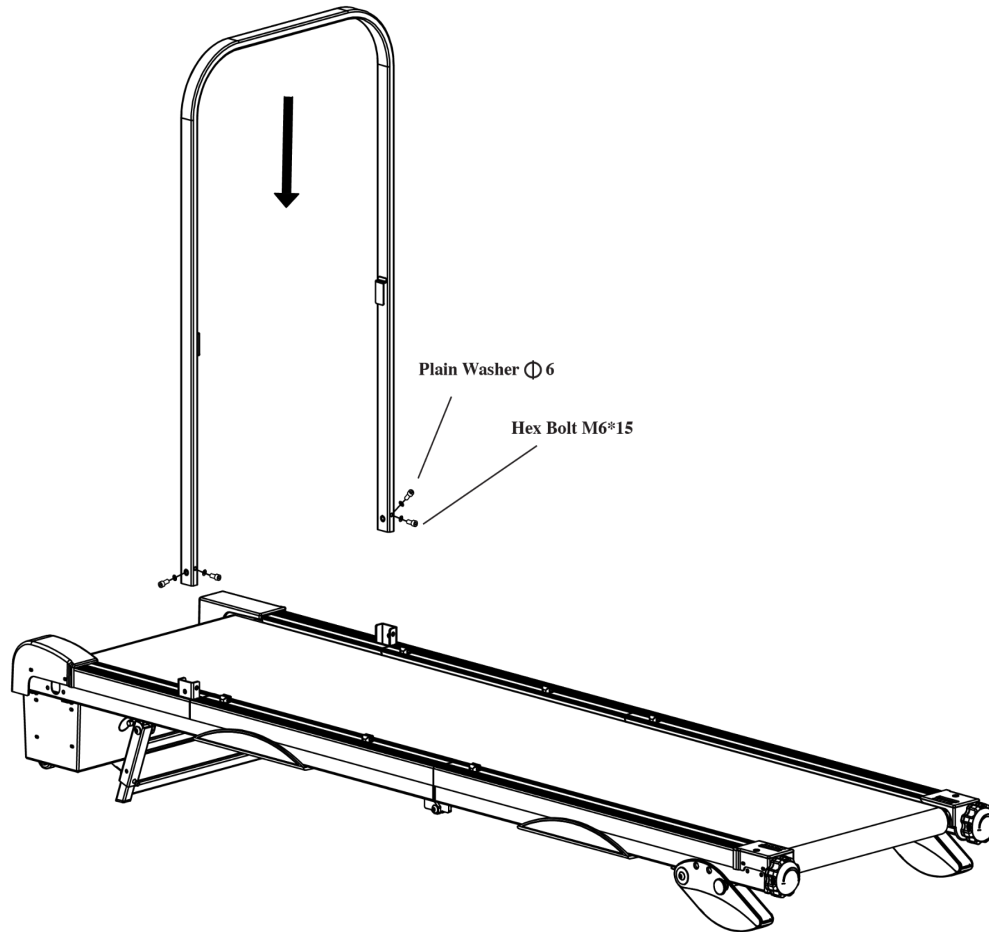

5. Connect the computer:

- Put the computer with the cable through the leg and connect the computer to the leg using ST4.2*12 screws (see diagram).
- Connect the computer with the cable connector.
- Connect the computer to the treadmill with two screws (M6*15 bolts).

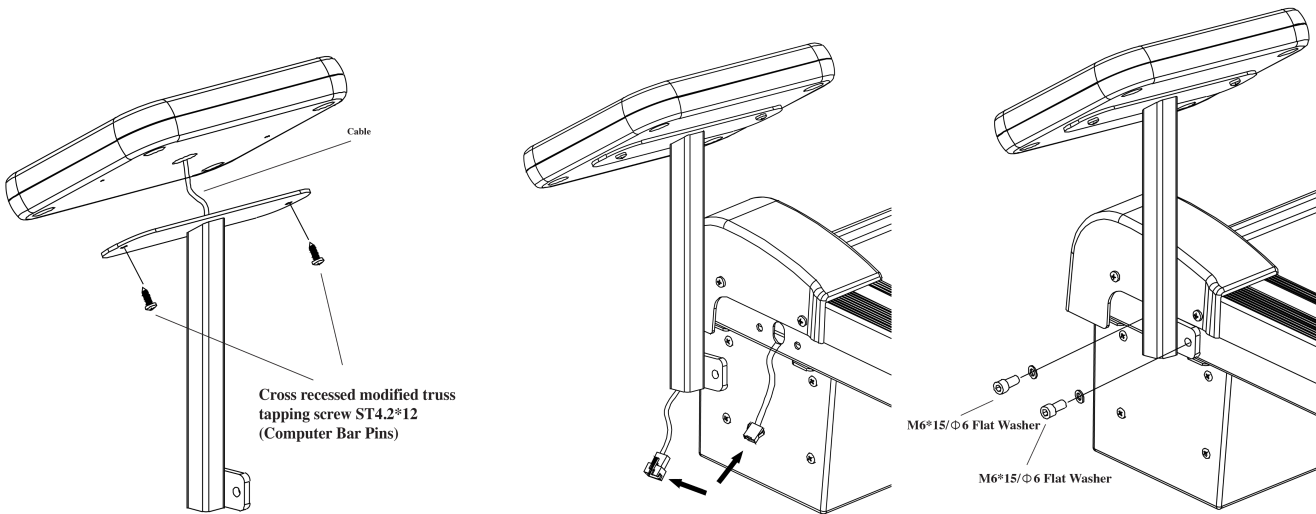

6. Attaching the Side Panels

1. When the dogPACER is in position, lay the side panel down on the belt.
2. Insert the side panel to the rubber clips (A, B & C) on the P.V.C. side rails.
3. Put the upper part of the side panel under the fixed clip on the upper bar.

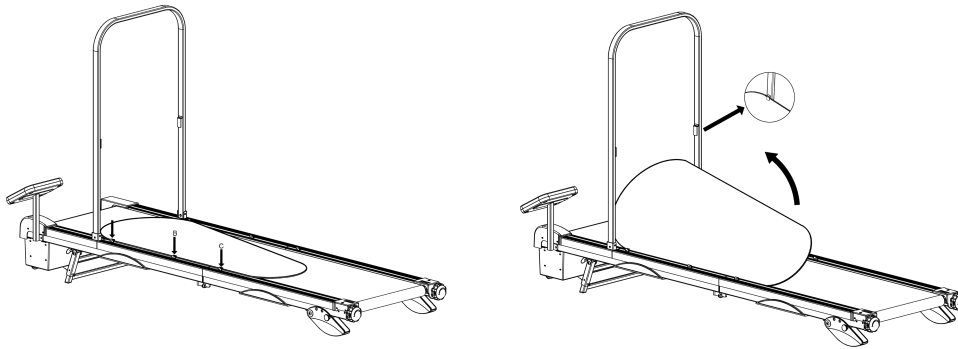

7. Applying Tension to the Belt

- When the belt is loose, starting at the front side and going back, center the belt using your hands.
- After you make sure the belt is centered, start turning the adjustment knobs together. The adjustment knob system is located on the back end caps.
- For the belt to have enough tension, it has to be between the numbers 2-3 on both sides of the back roller cover scale (see diagram). Use the white marker on the roller for better indication.
- If you cannot tighten the back roller mechanism with your hands, use the assistant poles (Ø8 Buld Bolt).

CAUTION: DO NOT OVERTIGHTEN

Over Tightening will cause belt damage and premature roller (bearing) failure.

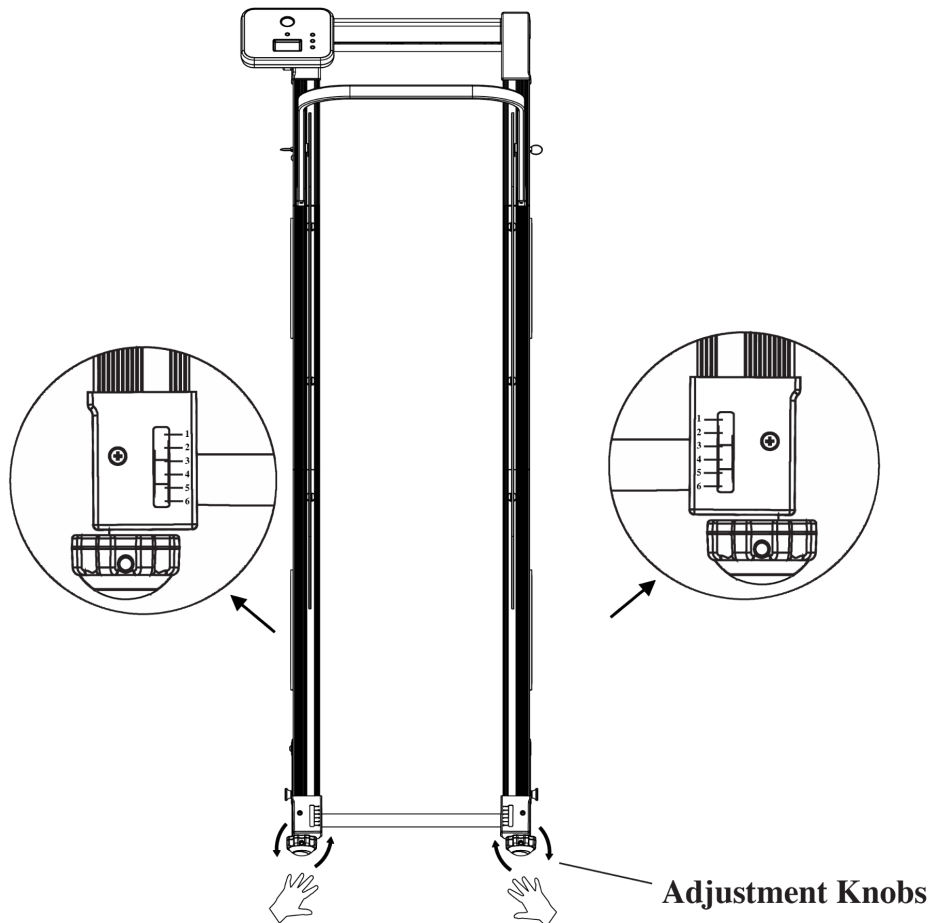

8. Connecting your dogPACER

Connect the power cable to the machine and an outlet. Make sure the Safety Key is in its place. Turn the switch to ON mode (amber light).

Computer console:

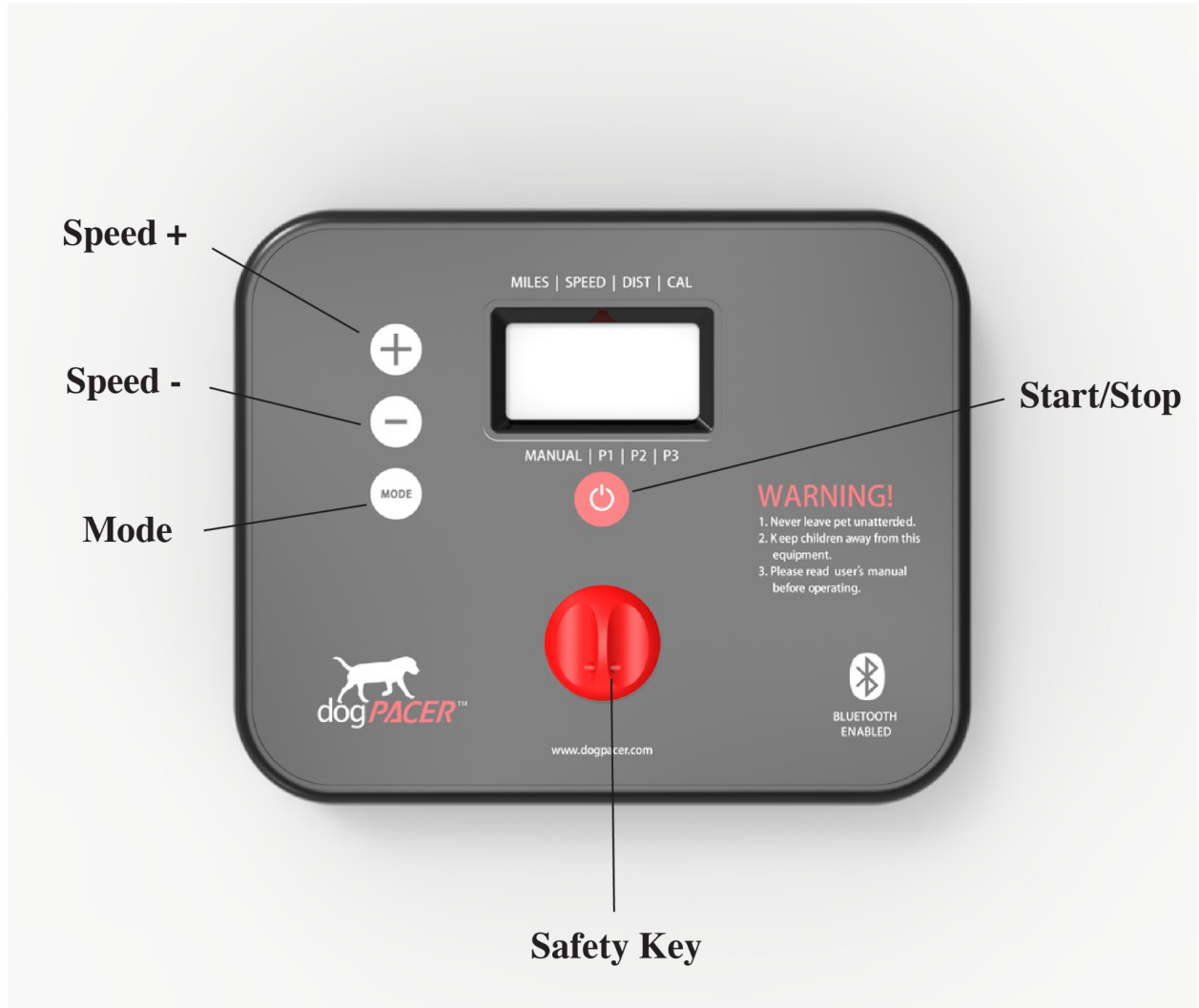

9. Belt Tracking Adjustment (before running)

- Start the treadmill by pushing the start/stop button.
- At minimum speed, go to the back of the dogPACER and see if the running belt stays in the middle. If it shifts to the right or left do the following:

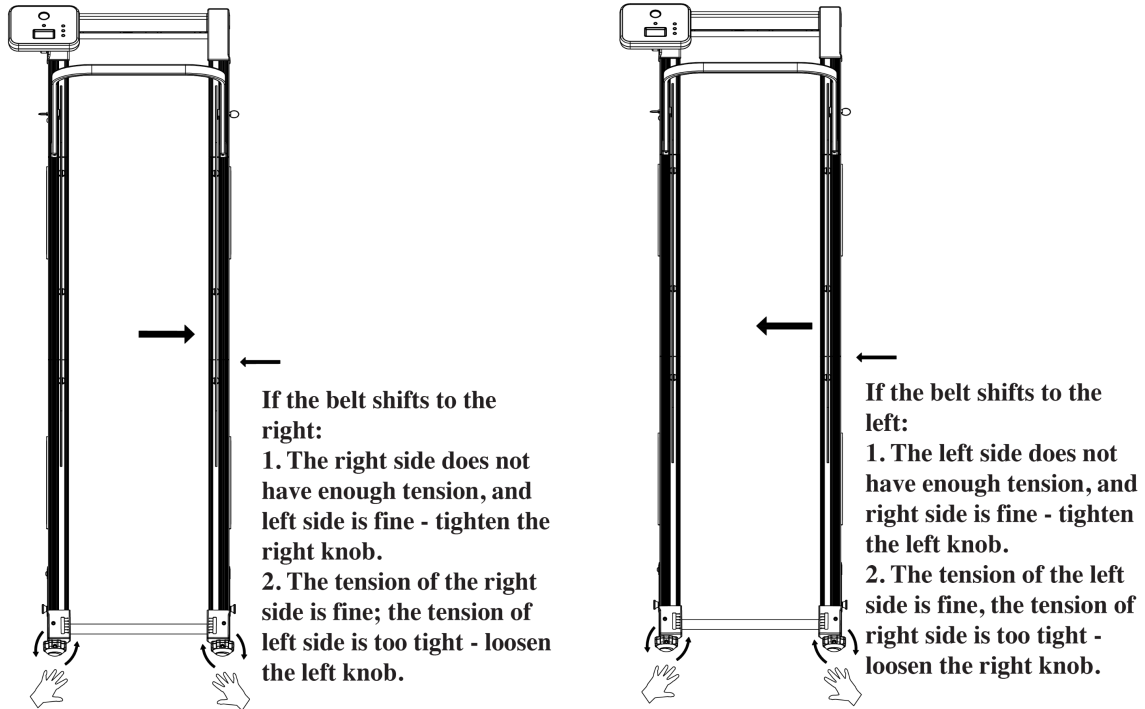

10. After Set Up – Quick Start Operation:

- Press and release the **START/STOP** to begin belt movement, at 0.5 MPH, then adjust to the desired speed using the '+' or '-'.
- To slow the treadmill down, press and hold the '-' key to desired speed.
- In a state of running, single press **START/STOP**, the walking belt will gradually slow down to a stop.

Calorie Display

Displays the cumulative calories burned at any given time during your pet's workout.

Note: This is only a rough guide used for comparison of different exercise sessions, which cannot be used for medical purposes.

Incline Feature

The dogPACER contains 4 manual incline positions from 5 degrees to 9 degrees

Pre-set programs

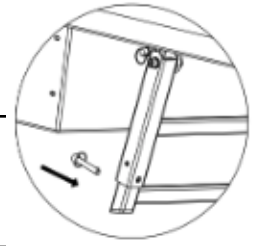

For any further information, troubleshooting, or help please see dogPACER user manual or go online to : www.dogpacer.com

Each pre-set program has a maximum time of 30 min per workout. It will always start at 10 min and can be adjusted per pet level. Choose from P1, P2, or P3 to give your pet the desired exercise. Each program has various speed changes throughout the program (see list of programs in user manual). Power on the machine, press ‘MODE’ to choose desired program, then press and release ‘START/STOP’ to begin the program with default values

Warranty: YOU HAVE 60 DAYS TO REGISTER THIS PRODUCT, VISIT: www.dogpacer.com

Technical support

dogPACER provides technical support. Please write an email to – info@dogpacer.com

For further information and help please see USER’S MANUAL or for FAQ’s and instructional videos go to: www.dogpacer.com

Bluetooth Connection

Thank you for purchasing our NEW dogPACER 4.0. We are so excited for you to get started using it. Please follow the steps below to get started:

1. Download the dogPACER APP from the Apple/Android store.
2. Turn the power on to your treadmill and open the app.
3. The treadmill should automatically connect.
4. Click the upper right hand corner to create your pets profile

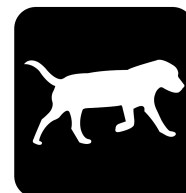

dogPACER

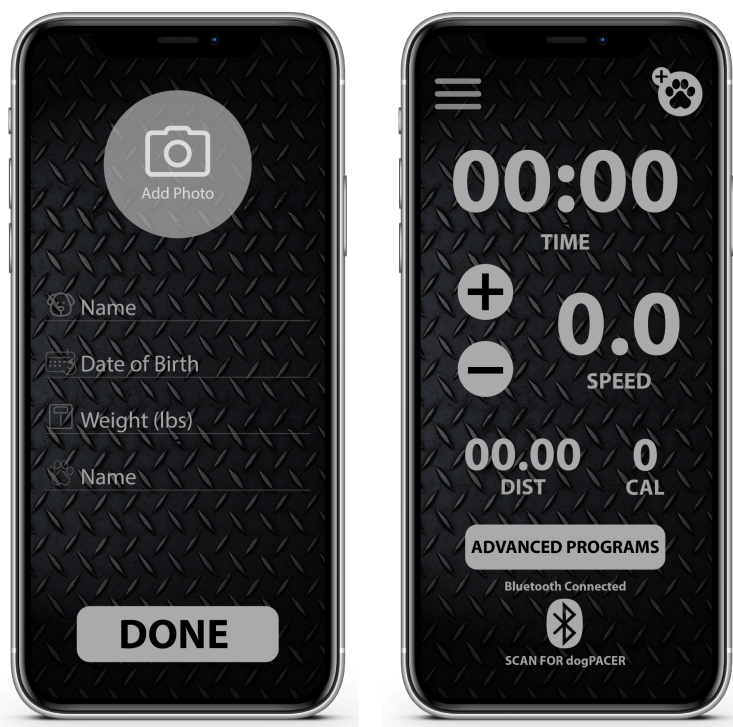

That's it! Once you have connected the APP and created the pet profile, you are ready to start running. Once your run is completed, you can share to anyone via social media, email or text message.

If you have any problems during the set up or while using your treadmill, please contact us at: 702-696-1900 or support@wagbrands.com

Happy Running!



YOUR DOG'S **OTHER** BEST FRIEND